



Sheet (6)... Magnetically Coupled Circuits

1. When a coil 1 of magnetically coupled pair has a current of 5A, the resulting fluxes Φ_{11} and Φ_{12} are 0.2mwb and 0.4mwb respectively. If $N_1=500$, $N_2=1500$ find L_1 , L_2 , M and K .
2. For circuits in fig1 and 2, find the equivalent inductance across terminals a, b.

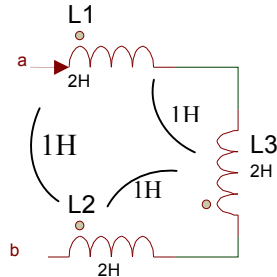

Figure 1

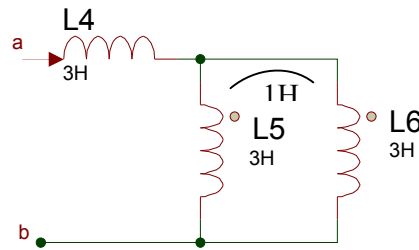

Figure 2

3. Calculate mutual inductance of two coils of self-inductance 100mH and 200mH which are connected in series to yield a total inductance of 146mH.
4. Three similar coils are wound on along common core in such way that the voltage of mutual inductance between each set of coils is positive. The self-inductance of each coil is 0.2H. The effective inductance of first two in series is 0.6H, and of all the three in series is 1H. When the terminals of the first coil are interchanged, the effective inductance of the three coils in series becomes 0.5H. Determine the coefficient of coupling between each set of coils.



5. In the circuit shown in fig. 3, determine V_1 , V_2 and V_3 .

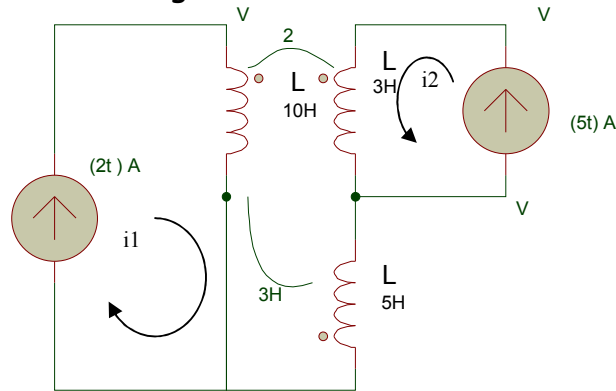

Figure 3

6. In the circuit shown in fig. 4 $L_2=2H$. The inductance at the terminals 1, 2 is 3H when the terminals 3, 4 are opened and 1H when shorted. Determine the coefficient of coupled circuit.

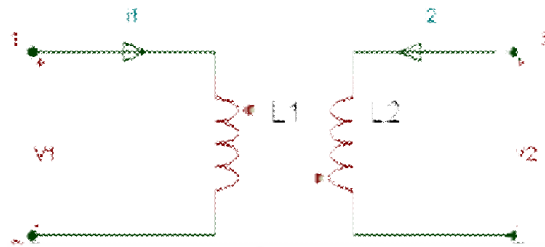
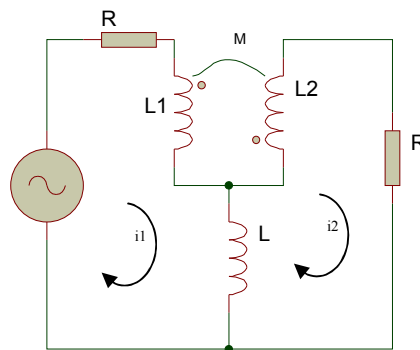

Figure 4

7. Find the ratio of I_1 and I_2 for the circuit shown in fig. 5 using the dotted coupled circuit shown, and then draw the conductively coupled equivalent circuit.



Good Luck